

CERTIFICATE

EU Type – Examination

According to Directive 2014/33/EU, (Module B, annex IV - A)
Certificate No: LF/KSA/A-C-0343/23

Identification No of Certification body:

MIRTEC s.a  0437

Name & Address
of the Certificate Holder:
of the Manufacturer:

**ZHEJIANG MATO DRIVE EQUIPMENT
CO., LTD.**

NO.188 YANGHUA ROAD, NANXUN TOWN, HUZHOU,
ZHEJIANG, CHINA

Date of Submission for
EU Type-Examination:

22/12/2023

Product of Safety Component:

**Electromechanical brake as ascending safety
device (ASD) to prevent uncontrolled upward
movement of the car and as unintended car
movement protection (UCMP) means**

Type:

MEPB

Applicable Standards:

2014/33/EU, annex I,
EN81-50:2020 5.7 & 5.8
EN81-20:2020 5.6.6 & 5.6.7, 5.9.2.2.2

Examination Period:

March 2024

Date & No of examination report:

LF/KSA/A-R-0343/23, 06/03/2024

Place of testing:

SHANGHAI JIAO TONG UNIVERSITY ELEVATOR TEST CENTER /
NO. 800 OF DONGCHUAN ROAD, SHANGHAI, P.R. CHINA.

Date & No of laboratory Report:

UCMP: ETC21F380028, 06/05/2021

ACOP: ETC21F350014, 06/05/2021

Documents annexed:
to the Certification:

Product description, Calculation book, Drawings,
Installation & maintenance instructions, Material list

Field of application:

ANNEX 1, ANNEX 2

Validation conditions / Additional instructions:

The production of the brake falls under random inspections from the certification body.

For all changes on the materials, drawings and production-assembly methods the certificate holder must inform the certification body.

The Certificate holder issues a declaration of conformity according to the basic requirements of the relative directive and places the CE marking with his own responsibility. The product must be accompanied by installation & maintenance instructions adjustment.

The brake should have a label with the necessary information (name of manufacturer, type examination certificate number, field of application, serial number, date etc).

Result of the examination - Declaration:

**Here with we certify that the type of the product mentioned above, meets the requirements of the
Directive 2014/33/EU.**

Only the products detailed in the test report have been subjected to tests.

Date of issue:

15.03.2024

For MIRTEC S.A.

I. DIMITRIADIS
Lead Auditor, Inspector of Lifts



Certification department for lifts

C. SPILIOPOULOS
Inspector of Lifts



EBETAMIRTEC

ANNEX 1



Product Certification
No. of Certificate 27

Part of the EU-Type examination LF/KSA/A-C-0343/23

Technical characteristics			
Model	MEPB	Type of stopping element	Synchronous motor brake
Acting position	Traction sheave shaft	Action method	Acting when power supply loss
Material of friction element	Non-asbestos composite	Type of elastic element	Cylindrical helical compression spring
Number of friction surfaces	2	Number of springs	2 × 12
Airgap	0.3 ~ 0.5 mm		
Brake torque	2 × 800 Nm		
Spring type	Ø3.2 × Ø 9.7 × 43		
Diameter of brake drum	278 mm		

A. Brake as ascending safety device (ASD) to prevent uncontrolled upward movement of the car

Field of application	
Brake torque	2 × 800 Nm
Range of rated load	630 ~ 1275 kg
Range of system mass	1282 ~ 3868 kg
Range of weight of car	515 ~ 1615 kg
Range of balance coefficient	0.4 ~ 0.5
Traction ratio	2:1
Rated speed	≤ 2.5 m/sec
Tripping speed range	≤ 3.15 m/sec
Max. rated rotational speed	300 rpm
Max. tripping rotational	387 rpm
Notes	<p>The range of the system mass and weight of car and rated load are determined according to the type-examination sample with the suspension ratio of 2:1, the values of other actual suspension ratios can be obtained by the following formulas:</p> <ol style="list-style-type: none"> 1) The applicable system mass = type-examination system mass × actual suspension ratio ÷ suspension ratio in type-examination; 2) The applicable weight of car = type-examination weight of car × actual suspension ratio ÷ suspension ratio in type-examination; 3) The applicable rated load = type-examination rated load × actual suspension ratio ÷ suspension ratio in type-examination.



EBETAMIRTEC



Product Certification
No. of Certificate 27

The maximum tripping speed of the lift and the nominal speed of the lift are being calculated based on the maximum tripping rotational speed and the nominal rotational speed of the traction sheave. Taking into account for this calculation the traction sheave diameter and the car suspension.

$$v = \frac{D * \pi * n}{60 * i}$$

D = diameter of the traction sheave (m)

$\pi = 3,14$

n = rotational speed (min⁻¹)

i = ratio of car suspension

V = lift speed (m/sec)

Remarks

- The permissible braking moments must be applied to the lift system in such a way that during the stopping phase, the braking element shall not allow a retardation of the car in excess of 1g for upwards movement with empty car.
- The installation conditions and connection requirements are described in the operating instructions.

Conditions

- The braking element also functions as a brake for normal operation. In the scope of this type examination, it was found out that there is built-in redundancy. For meeting the requirements to be used also as ascending safety device (ASD) to prevent uncontrolled upward movement of the car, must also has self-monitoring of correct operation.
- Self-monitoring could include verification of correct lifting or dropping of the mechanism or verification of the breaking force. This must applied on both brakes individually. If a failure is detected, car and landing doors shall be closed and the normal start of the lift shall be prevented.
- The braking element must impact directly on the traction sheave or on the same shaft in the immediate vicinity of the traction sheave. If the braking element does not impact on the traction sheave or on the same shaft in the immediate vicinity of the traction sheave, a deviation from the norm exists.
- The tests of the type examination sample performed with the suspension ratio of 2:1 and the range of the system mass, weight of car and rated load referred to the table are determined according this ratio. For use for other suspension ratio, the values of other actual suspension ratios can be obtained by the formulas referred to the notes in the table.

EBETAM A.E.

CERT – safecomp / EN.02 (5.0 / 10.2.17)

www.mirtec.gr

Εδρα: Α. Βουλιαδική Περιοχή, Τ.Κ. 15122 Αθήνα - Head office: A. Industrial Area, P.O. Box 13, GR-15122 Athens, Tel: +30 2471095340-2, E-mail: volas.office@mirtec.gr
 Γραφείο Αθηνών: Μεσογειακή οδός 4, 11527 Αθήνα - Athens Office: Melinas Merkouri 76, 17342 Agios Dimítrios Attikis, Tel: +30 210 9948432, E-mail: athens.office@mirtec.gr
 Γραφείο Θεσσαλονίκης: Βουλιαδική περιοχή, 570 22 Θεσσαλονίκη - Thessaloniki Office: Industrial Area, GR-570 22, Thessaloniki, Tel: +30 2310797867, E-mail: thess.office@mirtec.gr
 Παράρτημα Αθηνών: Ελ. Βενιζέλου 4, 176 76 ΜακΑθίδεα - Athens Branch: El. Venizelou 4, Gr-176 76 MakAthia, Tel: +30 2109234932, Email: athens.branch@mirtec.gr
 Παράρτημα Θηβών: 76ο χλμ. ΕΟ Αθηνών-Λαμίας, (Έλεος Πρωτόμας) Τ.Κ. 130, 32009, Σαγματούρι - Boeotia Branch
 Thiva Branch: 76 km of Athens - Lamia N.R. - P.O. Box 150, 32009 GR Sarmatari - Voiotas, Tel: +30 2262071811, E-mail: thiva.office@mirtec.gr
 Γραφείο Διοίκησης: Αγυθίωνισσού 6, 105 59 Αθήνα - Athens Administration Office: Drágalanissou 6, 105 59 Athens, Tel: +30 2160016990, E-mail: marketing@mirtec.gr

Requirements

- The safety component as a braking element is only a part of a protection system against the unintended car movement. The complete system, apart from the braking element, also consists of a detecting element and a triggering element. These components are subjected to their own type examination too. Only the correct combination of the three parts can create a system which fulfills the requirements for protection against UCM in accordance with EN 81-20 paragraph 5.6.7.
- The machine brake used in this system is an electro-mechanical brake according to 5.9.2.2.2 of the standard EN 81-20 and is considered to have built-in redundancy. The brake also is self-monitored. So it meets the point 5.6.7.3.
- The brake is acting on the sheave directly or in the immediate vicinity of the sheave. So it meets the point 5.6.7.4.
- The brake is activated by the loss of the power supply so it meets the point 5.6.7.12.
- The average retardation $\leq 1\text{gn}$ so it meets the point 5.6.7.6.

Conditions

- The tests have been made with the parameters and configuration that listed in this certificate. If these parameters or configuration have been changed, the tests must be done again and the certificate is no valid anymore.
- Self-monitoring, through the verification of correct lifting or dropping of the mechanism and verification of the breaking force, applied on both brakes individually. If a failure is detected, car and landing doors shall be closed and the normal start of the lift shall be prevented.
- The braking element must impact directly on the traction sheave or on the same shaft in the immediate vicinity of the traction sheave. If the braking element does not impact on the traction sheave or on the same shaft in the immediate vicinity of the traction sheave, a deviation from the norm exists.
- The installation conditions and connection requirements are described in the operating instructions.
- The tests of the type examination sample performed with the suspension ratio of 2:1 and the range of the system mass, weight of car and rated load referred to the table are determined according this ratio. For use for other suspension ratio, the values of other actual suspension ratios can be obtained by the formulas referred to the notes in the table.

Certification department of MIRTEC S.A.

C. SPILIOPOULOS



Size segmentation	0.5-3	>3-6	>6-30	>30-120	>120-400	>400-1000	>1000-2000	>2000-4000	Rounding and chamfering height dimensions	0.5-3	>3-6	>6-30	>30
m(Middling)	±0.1	±0.1	±0.2	±0.3	±0.5	±0.8	±1.2	±2	±0.2	±0.5	±1	±2	
Public errand	±0.1	±0.1	±0.2	±0.3	±0.5	±0.8	±1.2	±2	±0.2	±0.5	±1	±2	

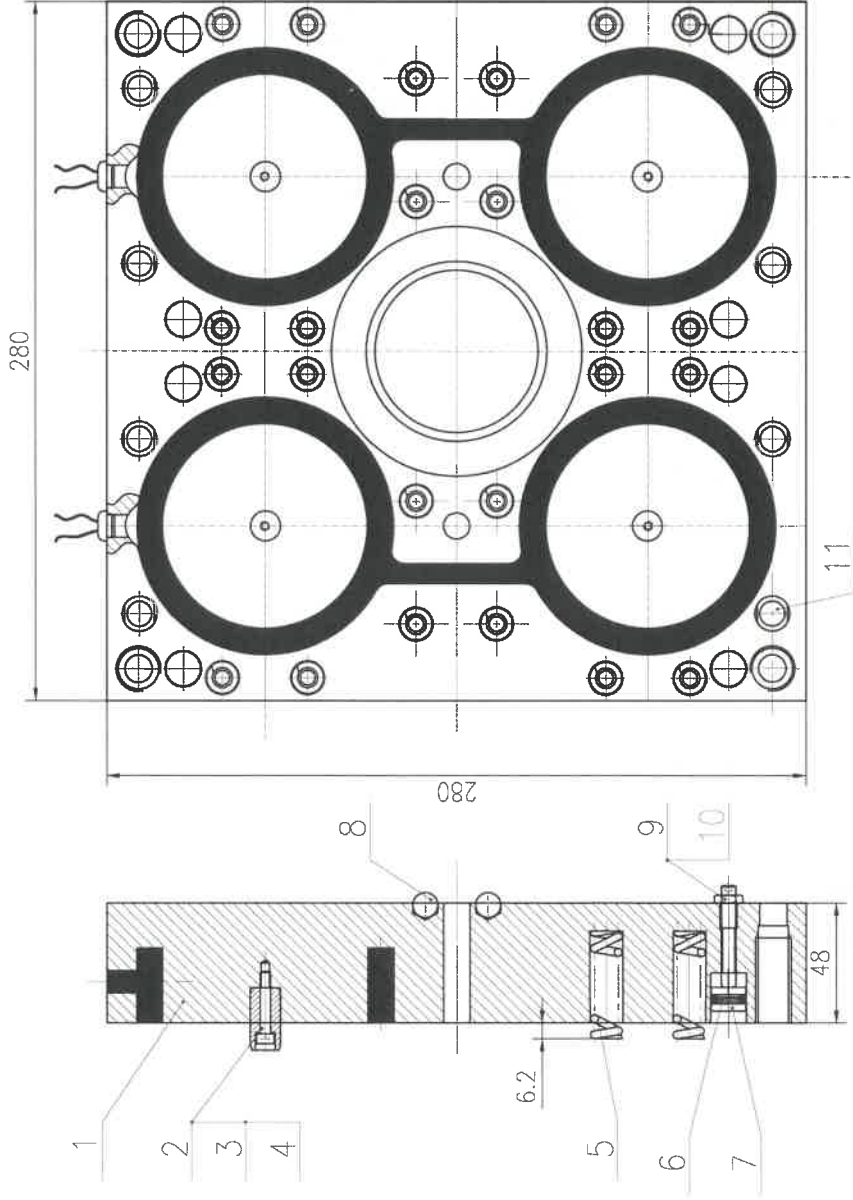

Technical requirements:

1. Protect the surface during assembly to avoid scratches;
2. The glue should be evenly applied, and the coil should be completely surrounded by the solution, but not higher than the surface of the iron core;
3. Conduct AC1200V withstand voltage test for 2 seconds without breakdown.



Part ID number: MTA1800Z_		_1	
Iron core material		Q355B	
Power cord color		Black	
Applicable model		MEPB	
Coil Voltage (V)		DC110	
Serial Number	Product name	Part ID number	Qty
1	Glued iron core	MTA1900Q1	1
2	Screw	GB/T70.1/M4×25	4
3	Lock washer	DIN9250/M4	4
4	Guidepost	MTA758B1	4
5	Brake spring	MTA90C1	24
6	Disc spring	DIN2093/14×0.9	32
7	Round pad iron	MTA40E1	16
8	Steel ball	GB/T308.1/10	8
9	Nut	GB/T6170/M6	8
10	Flat end set screw	GB/T777/M6×4.5	8
11	Shock pad	MTA745D1	8

MTA1800Z		Zhejiang MATO Drive Equipments Co., Ltd.	
Iron core components		Weight	
Yongyang	2020.12.07	Shenminjie	2020.12.07
Liahuguo	2020.12.07	Wujun	2020.12.07
PM1078A	Empower	Shiyujun	2020.12.07
Change content		Date	PM number
Number of locations	Changed by	Date	PM number

Size segmentation	0.5-3	>3-6	>6-30	>30-120	>120-400	>400-1000	>1000-2000	>2000-4000	Rounding and chamfering height dimensions	0.5-3	>3-6	>6-30	>30
m(Middling)	±0.1	±0.1	±0.2	±0.3	±0.5	±0.8	±1.2	±2		±0.2	±0.5	±1	±2



The remaining $\sqrt{6.3}$

$F_s = 1038N \pm 52N$
 $F_n = 750N \pm 37.5N$
 $F_1 = 687N \pm 34N$

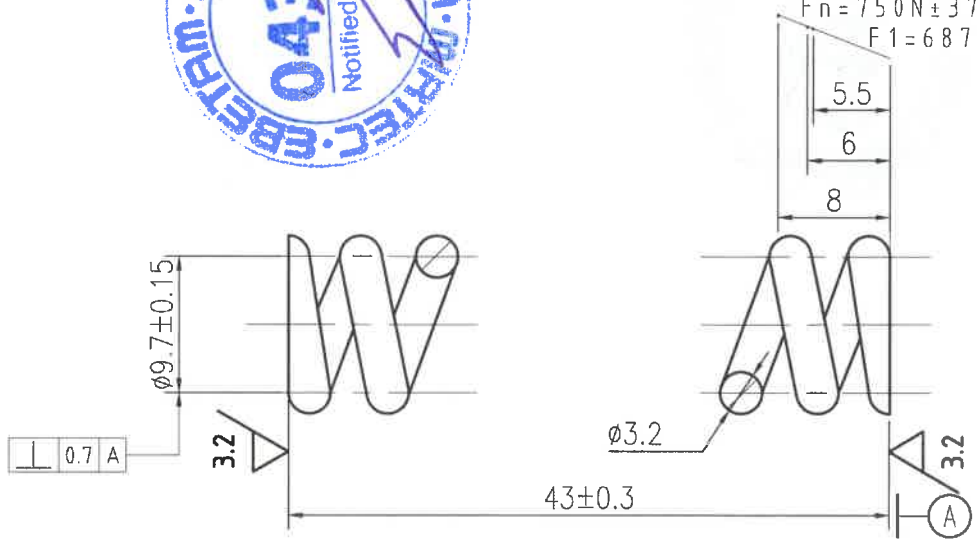

Technical requirements:

- 1.Total number of turns $n_1=11$, effective number of turns $n=9$
- 2.Rotation direction: Right rotation
- 3.End structure form: both ends ground flat
- 4.Stress relief annealing, surface blackening
- 5.The surface of the spring is smooth and must not have any visible defects to the naked eye
- 6.Unmarked tolerance based on spring level 2 manufacturing accuracy
- 7.After being compressed three times with F_j , the permanent deformation of the spring product shall not exceed 0.3% of the free height

Date	2013-10-09
Part ID number	MTA90C1
Application	MEPB

Mark	Number of locations	Change content				Changed by	Date	PM number
						MTA90C		55CrSiA
						Cylindrical bolt compression spring		Zhejiang MATO Drive Equipments Co., Ltd.
Design	Fangfei	2011.09.21	Standardization	Shenlu	2011.09.21	Stage markers	Weight	
Check	Shizhongming	2011.09.21	Ratify	Shijiasong	2011.09.22			
Technology	Qinxiaoming	2011.09.21	Empower	PM20110921001		Page 1 of 1		2: 1

Size segmentation	0.5-3	>3-6	>6-30	>30-120	>120-400	>400-1000	>1000-2000	>2000-4000	Rounding and chamfering height dimensions	0.5-3	>3-6	>6-30	>30
m(Middling)	±0.1	±0.1	±0.2	±0.3	±0.5	±0.8	±1.2	±2		±0.2	±0.5	±1	±2
Public errand													
Number of teeth	30												
M	2.5												
α	30°												
Tolerance level and fit	5H												
Dei	φ78.75 ^{+0.3} ₀												
E	φ3.927 ^{+0.077} _{-0.035}												
Fp	0.043												
Ff	0.025												
Fβ	0.011												

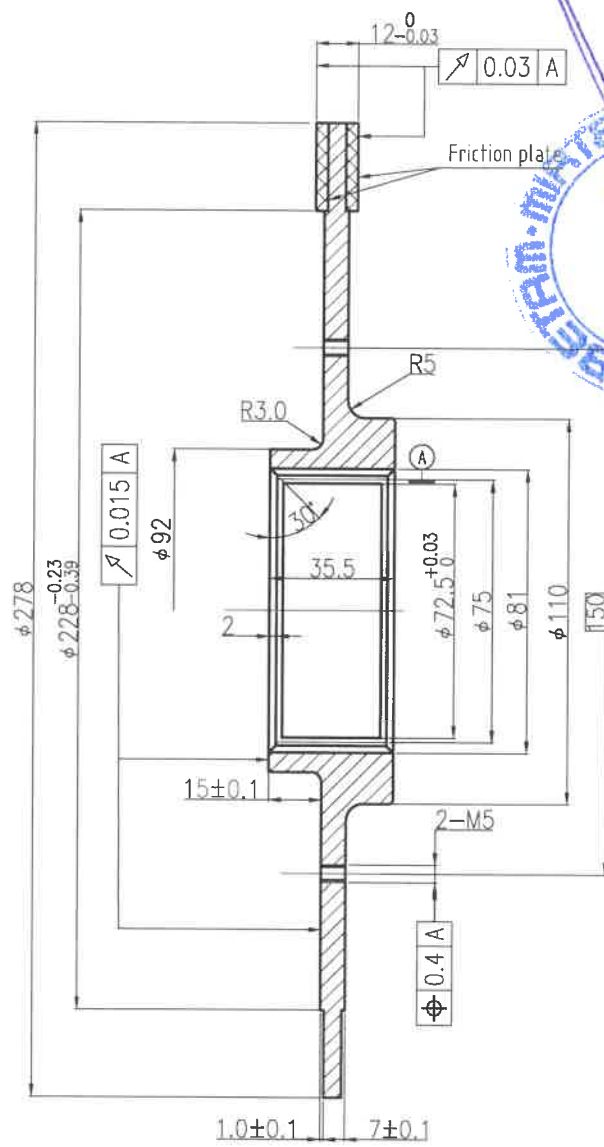

Technical requirements:

- There are no cracks on the outer surface and no associated objects on the edges;
- Friction coefficient $\mu > 0.4$;
- Wear rate $< 0.47 \times 10^{-2} \text{ cm}^3/\text{Nm}$, 250 °C;
- Friction plate Shore D hardness: 60-70;
- Good flame retardancy;
- Compression strength $> 25\text{MPa}$;
- Shear strength $> 2.5\text{MPa}$;
- The material must not contain asbestos;
- The limit deviation of the unmarked tolerance dimensions in the figure shall be in accordance with the above table;
- The friction plate must not contaminate oily substances.

Date	2020.12.07			
Part ID number:	MTA2700W1			
Applicable model	MEPB			
Serial Number	Product name	Part ID number	Material quality	Qty
1	Friction plate	/	WS series friction materials	1
2	Aluminum plate	MTA371H1	ZL107	1

Mark	Number of locations	Change content			Changed by	Date	PM number	
		MTA2700W						
		Friction disc assembly					Zhejiang MATO	
Design	Shenminjie	2020.12.07	Standardization	Yangyang	2020.12.07	Stage markers	Weight	Drive Equipments
Check	Wujun	2020.12.07	Ratify	Lishuguo	2020.12.07		2kg	Co., Ltd.
Technology	Shiyajun	2020.12.07	Empower	PM1078A		Page 1 of 1		1 : 2